

Kidney Loop System

**KLS
KLD**

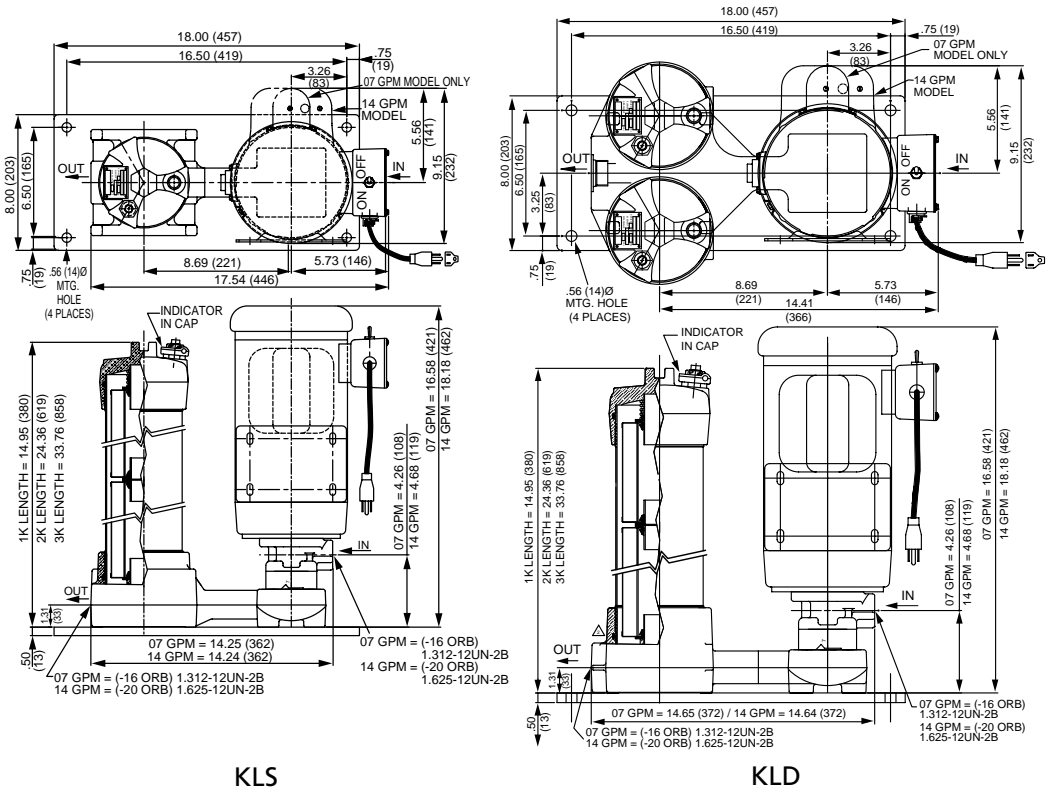
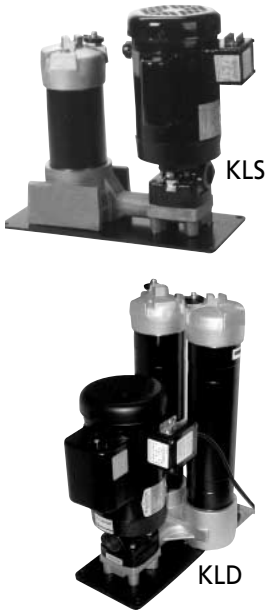

Metric dimensions in ().

Description

Schroeder's new off-line Kidney Loop System is a stationary version of the Mobile Filtration System. It is a compact, self-contained filtration system equipped with high efficiency, high capacity elements capable of removing particulate contamination and/or water quickly, conveniently and economically. This off-line system can be used to supplement in-line filters when adequate turnover cannot be achieved in the system. It is also ideal for water removal. Like the Mobile Filtration System, the new Kidney Loop System operates at a surprisingly low noise level. Its modular base eliminates hoses and fittings between components. The KLS single filtration unit can remove either water or particulate contamination. The KLD dual filtration unit can be used to remove both water and particulate contamination, or for staged particulate contaminant removal.

Features

- Modular base eliminates connections between components and minimizes leakage
- Base-ported filter provides easy element service from the top cap
- Single, double and triple bowl length option allows the flexibility of additional dirt holding capacity
- D5 Dirt Alarm® indicates when filter element needs changed

Kidney Loop System

- Supplementing in-line filtration by system filters when adequate turnover cannot be attained
- Large volume systems requiring multiple filters in different locations
- Cleaning up a hydraulic system following component replacement
- Ideal location for water removal

Applications

Mobile
Filtration
Systems

Air-Operated
Mobile
Filtration
Systems

**Kidney Loop
System**

Air-Operated
Kidney Loop
System

Auto Flush
Filter Cart

Filtration Station

X Series
Filter Skids

Specifications

Flow Rating:	7 gpm max. or 14 gpm max.
Maximum Viscosity:	1000 SUS (216 cSt) Higher viscosity version available. Contact factory for details.
Maximum Operating Temperature:	-20°F to 150°F (-29°C to 65°C)
Bypass Valve Setting:	Cracking: 30 psi (2 bar)
Material:	Manifold and cap: Cast aluminum Element case: Steel
Compatibility:	All petroleum based hydraulic fluid. Contact factory for use with other fluids.
Motor:	115V AC single phase 3/4 hp (7 gpm) or 1-1/2 hp (14 gpm)
Weight:	KLS-1: 101 lb. KLD-1: 117 lb. KLS-2: 112 lb. KLD-2: 139 lb. KLS-3: 123 lb. KLD-3: 161 lb.

Model Number Selection

Catalog Model Number	No. of Elements	Element Length	Element Media First Filter	First Media Second Filter (KLD Only)***	Seals	Pump Size (gpm)
KLS	1	09	E*, Z, EWR** plus 01, 03 05, 10, 25	E*, Z, EWR** plus 01, 03 05, 10, 25	B = Buna N V = Viton	07
		18				
		27				
KLD	2	09				14
		3				

Notes:

*E media elements are only available in 03, 10 and 25 microns.

**Water removal (W) elements are indicated by an "EWR" in the part number and are not followed by a 01, 03, 05, 10 or 25.

***When KLD is ordered, the number of elements, element length, and seals will be identical for both filter housings.